

FONTANA ATLANTA BRUSHED CHROME COMMERCIAL DECK MOUNT TOUCHLESS ELECTRONIC SOAP DISPENSER SPECS

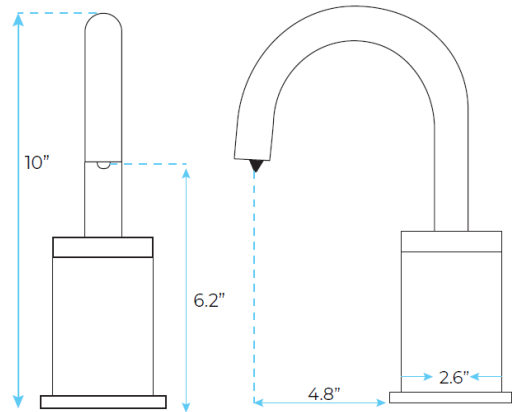

SPECS:

Product Type: Commercial

Main Construction Material: Brass

Mount Type: Deck

Sensor type: Active Infrared, Self-Adjusting

Power Rating: 4 (D) Batteries / AC Adapter
Optional

Soap Pump: 6 Volt Noise-Free

Number of Tap Holes: 1

Valve/Cartridge Type: Solenoid Valve

Plumbing System Requirements: Suitable
for all plumbing systems

Sensing Range: Adjustable with remote
control

Activation Time: 0.5 - 1 secs

Soap Bottle Capacity: 800ML optional 1
gallon containers

Soap Amount Per Use: 0.5ML to 1.5ML
(adjustable)

